



川源(中国)机械有限公司
GSD (China) Co., Ltd.

A low-angle photograph of several modern skyscrapers with glass facades, set against a clear blue sky. The buildings are the background for the top half of the page.

LPS

立式管道离心泵

LPS pipe centrifugal pump

LPS 立式管道离心泵

LPS Pipe centrifugal pump



用途 Application

- 暖通空调冷热水循环
- 工业、城市给水
- 高层建筑增压送水
- 消防给水
- 设备配套
- 锅炉给水
- 农业灌溉用水

- Apply to air-condition cold or hot water circulation;
- Industrial water and municipal water supply;
- Used to increase pressure and supply water for high buildings;
- Fire-fighting water system;
- Can be used together with equipment;
- Boiler water supply;
- Farm water irrigation.

特点 Features

- 品种齐全，适用性强。
- 同轴直接式构造，效率高，体积小，重量轻，安装保养容易。
- 采用进口轴承，振动小，噪音低。
- 采用机械密封，保证不损轴心，不漏水，使用寿命长。
- 叶轮采用优秀水力模型，性能稳定、制造精良，具有极好的动静平衡。
- 主轴采用不锈钢调质处理。
- 采用针式排气阀，操作简便。
- 可根据要求采用不同材质。（本型录为铸铁材质，不锈钢重量及尺寸另行提供。）

- Complete assortments and strong applications.
- Coaxial shaft structure, high efficiency, space-saving design, lightweight, easy installation and maintenance.
- The pump which is supported by imported bearing, runs at little vibration and low noise.
- Mechanical seal, no damage to shaft, no leakage, long duration.
- The optimal hydraulic model is used for impeller, the pump is of an utmost dynamic-static balance and reliable performance.
- The shaft is made of quenching and tempering stainless.
- Using needle type vent, simple operation.
- Can choose other materials according to the customer's requirement. (Material of the pump in the castalog is cast iron. Stainless steel can be provided separately.)



型号说明 Type description

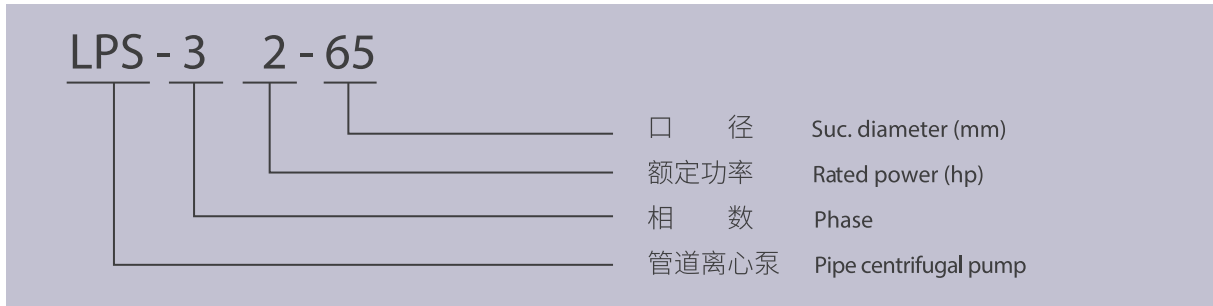

结构简图 Construction

NO.	名称	Name	材质		Material	
			GB	JIS		
1	电机	Motor	-	-	-	-
2	机械密封	Mechanical seal	C/AL ₂ O ₃	C/AL ₂ O ₃	C/AL ₂ O ₃	C/AL ₂ O ₃
3	针式排气阀	Needle type veut	ZCuPb10Sn10	LBC3	ZCuPb10Sn10	LBC3
4	中承座	Bracket	HT200	FC200	HT200	FC200
5	叶轮	Impeller	HT200	FC200	HT200	FC200
6	泵体	Pump casing	HT200	FC200	HT200	FC200
7	丝堵	Plug	Q235A	SS400	Q235A	SS400
8	键	Key	45	S45C	45	S45C
9	O形圈	O-ring	NBR	NBR	NBR	NBR
10	密封环	Seal ring	ZCuPb10Sn10	LBC3	ZCuPb10Sn10	LBC3
11	螺栓	Bolts	Q235A	SS400	Q235A	SS400

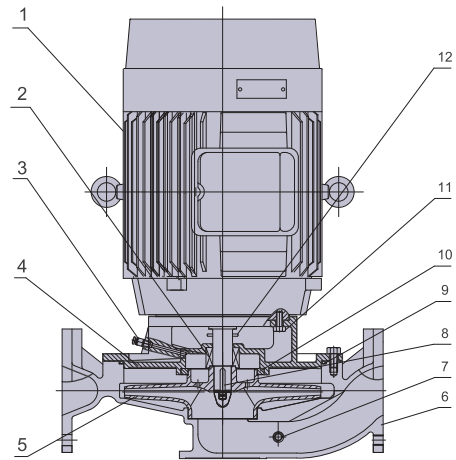

安装示意图 Installation sketch map

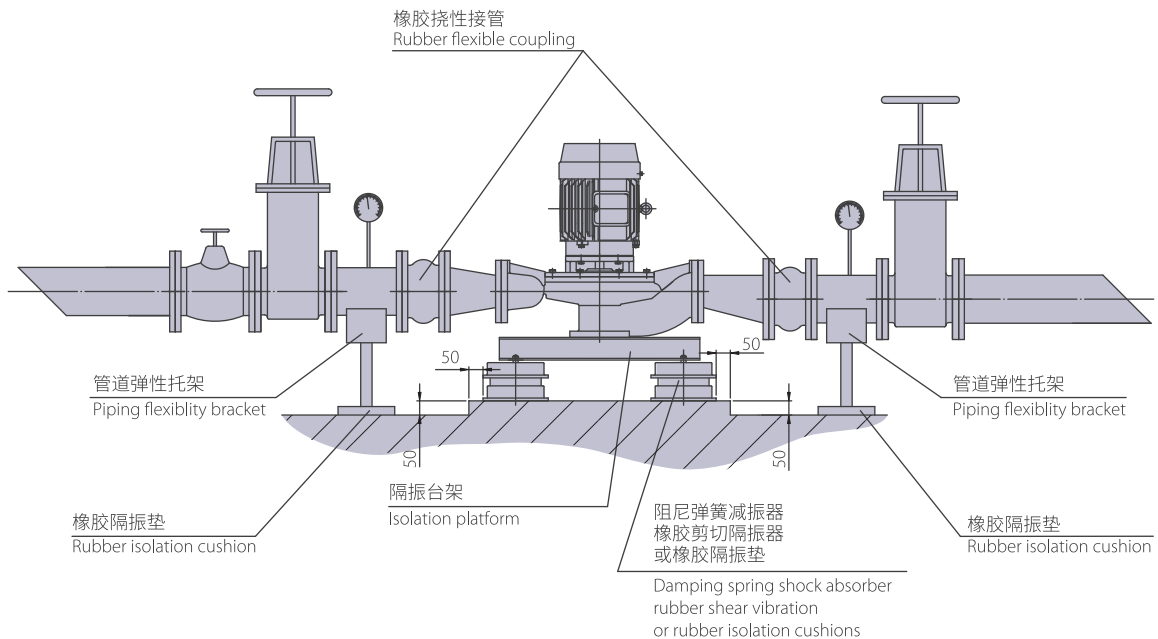

型谱图 Performance chart

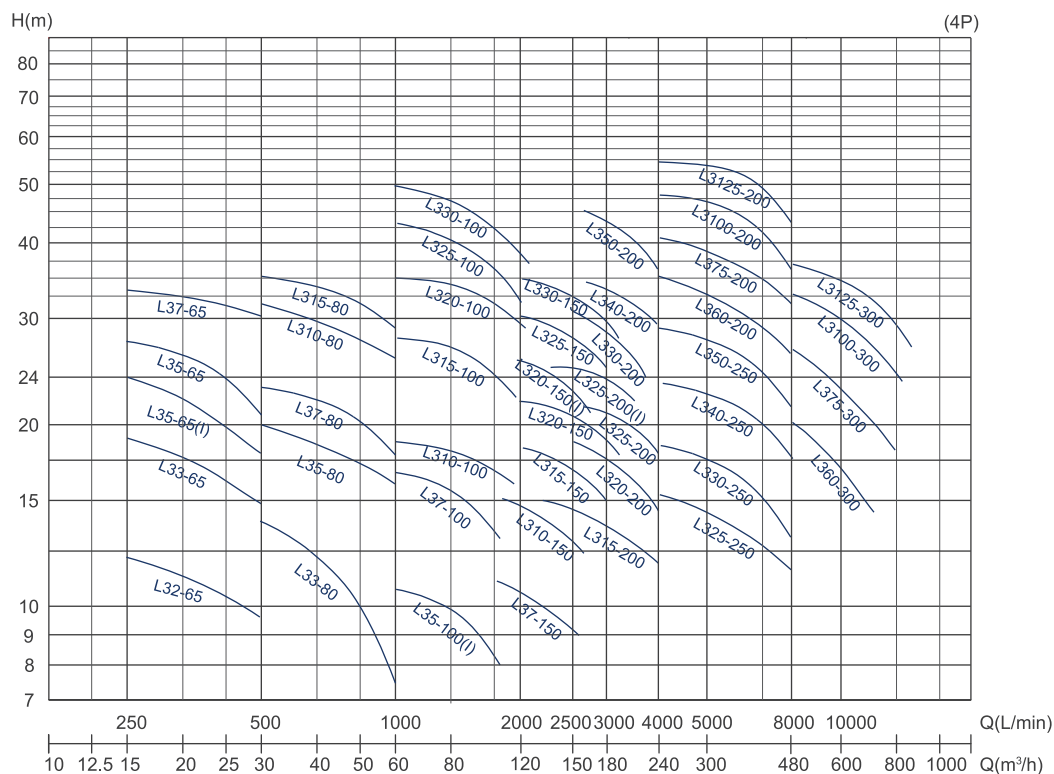
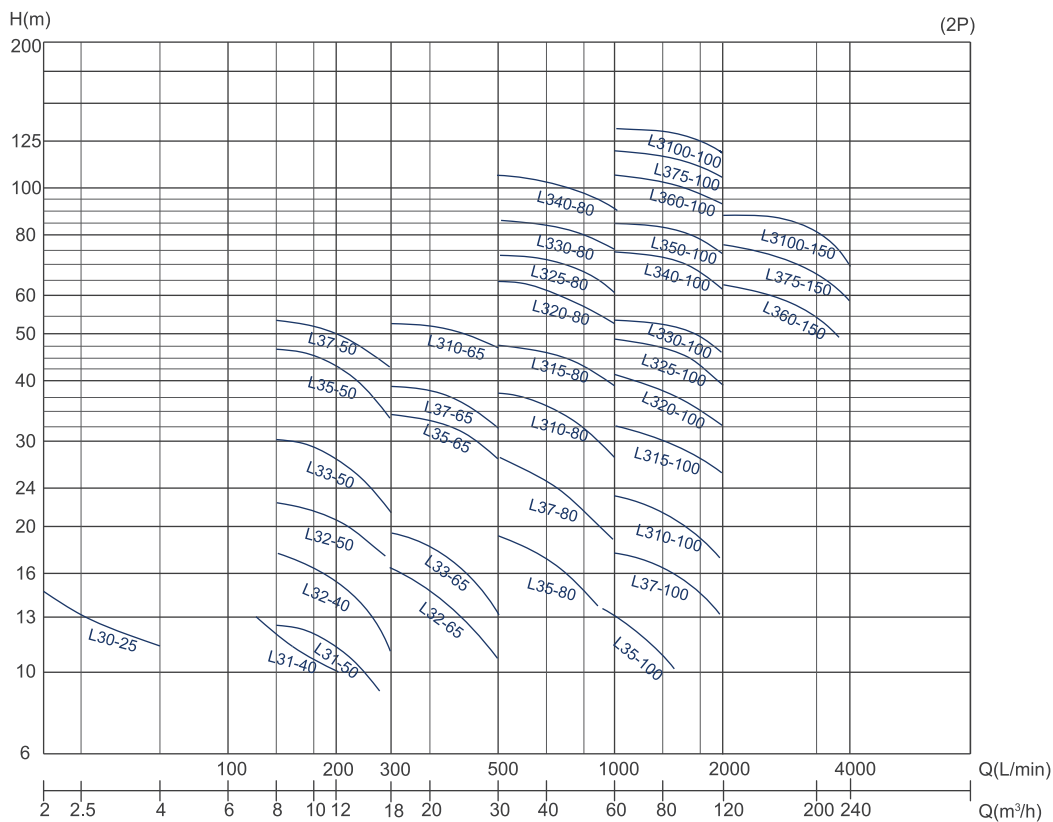

性能参数 Performance parameters

(2P)

型号 Type	转速 Speed (r/min)	流量 Capacity (m ³ /h)	扬程 Head (m)	效率 Eff. (%)	电动机功率 Motor power		必须气蚀余量 NPSHr (m)	口径 Dia. (mm)	重量 Weight (kg)
					(hp)	(kW)			
L-30-25	2900	2.0	15	30	0.5	0.37	2.5	25	24
		2.5	13	35			2.5		
		3.0	12	34			3.0		
L-31-40	2900	7.2	13	55	1	0.75	2.5	40	31
		9	11.5	60			2.5		
		10.8	10.5	58			3.0		
L-32-40	2900	8.8	17.5	57	2	1.5	2.5	40	39
		11	16	62			2.5		
		13.2	14	61			3.0		
L-31-50	2900	9.4	11	56	1	0.75	2.5	50	35
		11.7	10	60			2.5		
		14	9	59			3.0		
L-32-50	2900	8.8	21.5	56	2	1.5	2.5	50	42
		12.5	20	62			2.5		
		16.3	17.8	61			3.0		
L-33-50	2900	9.4	29.5	46	3	2.2	2.5	50	52
		11.7	28	54			2.5		
		14	25	53			3.0		
L-35-50	2900	9.4	46	46	5	3.7	2.5	50	72
		11.7	44	50			2.5		
		13	40	49			3.0		
L-37-50	2900	10	52	46	7.5	5.5	2.5	50	89
		12.5	50	48			2.5		
		15	47	47			3.0		
L-32-65	2900	16.8	16.5	66	2	1.5	2.5	65	45
		21	15	71			2.5		
		25.2	13	70			3.0		
L-33-65	2900	16	20	67	3	2.2	2.5	65	51
		22.3	18	70			2.5		
		29	14	69			3.0		
L-35-65	2900	20	33.5	63	5	3.7	2.5	65	75
		25	32	66			2.5		
		30	28.5	65			3.0		
L-37-65	2900	17.4	40.5	54	7.5	5.5	2.5	65	90
		21.7	38	60			2.5		
		26	34	56			3.0		
L-310-65	2900	20	51.5	57	10	7.5	2.5	65	95
		25	50	60			2.5		
		30	47	59			3.0		
L-35-80	2900	35.8	18	72	5	3.7	3.0	80	75
		44.7	16	74			3.0		
		53.6	14	68			3.5		
L-37-80	2900	34.6	26	66	7.5	5.5	3.0	80	101
		43.3	24	72			3.0		
		52	21	70			3.5		
L-310-80	2900	32	38	60	10	7.5	3.0	80	107
		40	36	68			3.0		
		48	33	66			3.5		
L-315-80	2900	37.4	46.5	61	15	11	3.0	80	150
		46.8	44	68			3.0		
		56.2	41	66			3.5		
L-320-80	2900	34.6	64	58	20	15	3.0	80	178
		43.3	60	64			3.0		
		52	57	59			3.5		
L-325-80	2900	37	73.5	50	25	18.5	3.0	80	200
		46.8	70	62			3.0		
		56	65	60			3.5		
L-330-80	2900	40	84	54	30	22	3.0	80	230
		50	80	62			3.0		
		60	75	61			3.5		
L-340-80	2900	36.4	108	54	40	30	3.0	80	360
		45.4	103	63			3.0		
		54.5	93	62			3.5		
L-35-100	2900	56	13.5	66	5	3.7	4.0	100	79
		70	12	74			4.0		
		84	10	72			4.5		
L-37-100	2900	68	17.5	68	7.5	5.5	4.0	100	102
		85	16	76			4.0		
		102	14	75			4.5		



性能参数 Performance parameters

(2P)

型号 Type	转速 Speed (r/min)	流量 Capacity (m ³ /h)	扬程 Head (m)	效率 Eff. (%)	电动机功率 Motor power		必须气蚀余量 NPSHr (m)	口径 Dia. (mm)	重量 Weight (kg)
					(hp)	(kW)			
L-310-100	2900	72	22.5	69	10	7.5	4.0	100	102
		90	20	77			4.0		
		108	18	75			4.5		
L-315-100	2900	72	31.5	71	15	11	4.0	100	161
		90	28	77			4.0		
		108	21	60			4.5		
L-320-100	2900	69.2	40	68	20	15	4.0	100	187
		86.6	38	75			4.0		
		102	34.5	72			4.5		
L-325-100	2900	74.8	46	68	25	18.5	4.0	100	221
		93.5	44	76			4.0		
		112.2	40	73			4.5		
L-330-100	2900	80	52.5	68	30	22	4.0	100	276
		100	50	75			4.0		
		120	46	74			4.5		
L-340-100	2900	74.8	74	65	40	30	4.0	100	307
		93.5	70	71			4.0		
		112.2	64	69			4.5		
L-350-100	2900	80	84	65	50	37	4.0	100	388
		100	80	70			4.0		
		120	72	69			4.5		
L-360-100	2900	72	105	54	60	45	4.0	100	472
		90	100	62			4.0		
		108	92	60			4.5		
L-375-100	2900	76	118	58	75	55	4.0	100	562
		95.5	114	64			4.0		
		114	102	63			4.5		
L-3100-100	2900	80	130	59	100	75	4.0	100	697
		100	125	66			4.0		
		120	118	65			4.5		
L-360-150	2900	144	61	69	60	45	4.5	150	400
		180	58	77			4.5		
		216	52	74			5.0		
L-375-150	2900	150	76	70	75	55	4.5	150	508
		187	70	78			4.5		
		224	64	75			5.0		
L-3100-150	2900	160	86	70	100	75	4.5	150	770
		200	80	78			4.5		
		240	72	76			5.0		



性能参数 Performance parameters

(4P)

型号 Type	转速 Speed (r/min)	流量 Capacity (m ³ /h)	扬程 Head (m)	效率 Eff. (%)	电动机功率 Motor power		必须气蚀余量 NPSHr (m)	口径 Dia. (mm)	重量 Weight (kg)
					(hp)	(kW)			
L-32-65	1450	18.7	11.8	56	2	1.5	3.0	65	70
		23.4	11	65			3.0		
		28	10.2	62			3.5		
L-33-65	1450	18.4	18.3	53	3	2.2	3.0	65	90
		23	17	60			3.0		
		27.6	15.5	56			3.5		
L-35-65	1450	17.6	27	44	5	3.7	3.0	65	111
		22	25	53			3.0		
		26.4	22.5	51			3.5		
L-35-65(I)	1450	20	22	54	5	3.7	3.0	65	120
		25	20	59			3.0		
		30	18.5	56			3.5		
L-37-65	1450	20	33	48	7.5	5.5	3.0	65	103
		25	32	52			3.0		
		30	30.8	50			3.5		
L-33-80	1450	32	14	65	3	2.2	3.0	80	112
		40	12	70			3.0		
		48	9	68			3.5		
L-35-80	1450	37	18.7	60	5	3.7	3.0	80	95
		46.7	17	68			3.0		
		56	16.6	64			3.5		
L-37-80	1450	40	22	60	7.5	5.5	3.0	80	126
		50	20	69			3.0		
		60	18	65			3.5		
L-310-80	1450	37	30	56	10	7.5	3.0	80	164
		46.7	28	63			3.0		
		56	26.5	61			3.5		
L-315-80	1450	40	34.2	60	15	11	3.0	80	198
		50	32	63			3.0		
		60	29	62			3.5		
L-35-100(I)	1450	69.2	10.5	66	5	3.7	3.0	100	120
		86.5	9.5	75			3.0		
		103.8	8	70			3.5		
L-37-100	1450	69.2	16.6	67	7.5	5.5	3.0	100	143
		86.5	15	75			3.0		
		103.8	13.2	72			3.5		
L-310-100	1450	74.8	18.5	69	10	7.5	3.0	100	185
		93.5	17.5	74			3.0		
		112.2	16	73			3.5		
L-315-100	1450	72.6	27.2	62	15	11	3.0	100	260
		90.8	25.8	71			3.0		
		109	22.8	68			3.5		
L-320-100	1450	80	34.5	67	20	15	3.0	100	282
		100	32	72			3.0		
		120	29	71			3.5		
L-325-100	1450	72	40	62	25	18.5	2.5	100	340
		90	38	68			2.5		
		108	35.5	65			3.0		
L-330-100	1450	76	47	60	30	22	2.5	100	410
		95	44	66			2.5		
		114	38	63			3.0		
L-37-150	1450	108	11	71	7.5	5.5	3.0	150	200
		130	10	77			3.0		
		156	9	74			3.5		
L-310-150	1450	107	15	71	10	7.5	3.0	150	230
		134	14	79			3.0		
		160	12.5	78			3.5		
L-315-150	1450	120	18.5	74	15	11	3.0	150	270
		147	17	79			3.0		
		180	15	78			3.5		
L-320-150	1450	128	21.5	75	20	15	3.0	150	317
		160	20	80			3.0		
		192	18	78			3.5		
L-320-150(I)	1450	110	26	70	20	15	3.0	150	317
		138	24	77			3.0		
		166	21	74			3.5		
L-325-150	1450	120	30	70	25	18.5	3.0	150	338
		150	28	78			3.0		
		180	25	75			3.5		



性能参数 Performance parameters

(4P)

型号 Type	转速 Speed (r/min)	流量 Capacity (m ³ /h)	扬程 Head (m)	效率 Eff. (%)	电动机功率 Motor power		必须气蚀余量 NPSHr (m)	口径 Dia. (mm)	重量 Weight (kg)
					(hp)	(kW)			
L-330-150	1450	128	34.8	70	30	22	3.0	150	400
		160	32	78			3.0		
		192	28	75			3.5		
L-315-200	1450	133	15	68	15	11	3.0	200	285
		167	14	78			3.0		
		200	13	75			3.5		
L-320-200	1450	148	19	72	20	15	3.0	200	323
		185	17	78			3.0		
		222	15	77			3.5		
L-325-200	1450	160	21.5	72	25	18.5	3.0	200	350
		200	20	78			3.0		
		240	18	76			3.5		
L-325-200(I)	1450	138	25	70	25	18.5	3.5	200	350
		173	24	77			3.5		
		208	22	75			4.0		
L-330-200	1450	148	31	72	30	22	3.5	200	418
		185	28	78			3.5		
		222	24	77			4.0		
L-340-200	1450	160	34.6	72	40	30	3.5	200	487
		200	32	79			3.5		
		240	30	78			4.0		
L-350-200	1450	176	43	70	50	37	3.0	200	503
		200	40	76			3.5		
		264	36	72			4.0		
L-360-200	1450	256	35	73	60	45	4.0	200	515
		320	32	79			4.0		
		384	29	78			4.5		
L-375-200	1450	276	40	71	75	55	4.0	200	585
		346	38	78			4.0		
		415	36	77			4.5		
L-3100-200	1450	258	48	75	100	75	4.0	200	790
		374	44	79			4.0		
		430	38	77			4.5		
L-3125-200	1450	240	55	74	125	90	4.0	200	810
		400	50	81			4.0		
		460	45	76			4.5		
L-325-250	1450	264	15	73	25	18.5	4.5	250	382
		330	14	78			5.0		
		396	13	76			5.5		
L-330-250	1450	288	18	73	30	22	5.0	250	435
		360	16	80			5.0		
		432	14	78			5.5		
L-340-250	1450	320	22	74	40	30	5.0	250	508
		400	20	80			5.0		
		480	17	79			5.5		
L-350-250	1450	304	28	72	50	37	5.0	250	530
		380	26	80			5.0		
		456	22	78			5.5		
L-360-300	1450	500	19.5	75	60	45	5.0	300	750
		600	17	80			5.0		
		700	15	78			5.5		
L-375-300	1450	480	26	73	75	55	5.0	300	795
		600	24	79			5.0		
		720	20	78			5.5		
L-3100-300	1450	528	31	76	100	75	5.0	300	1050
		660	28	83			5.0		
		792	25.5	80			5.5		
L-3125-300	1450	576	34	78	125	90	5.0	300	1200
		720	32	83			5.0		
		864	27	81			5.5		



外形及安装尺寸 Installation dimensions

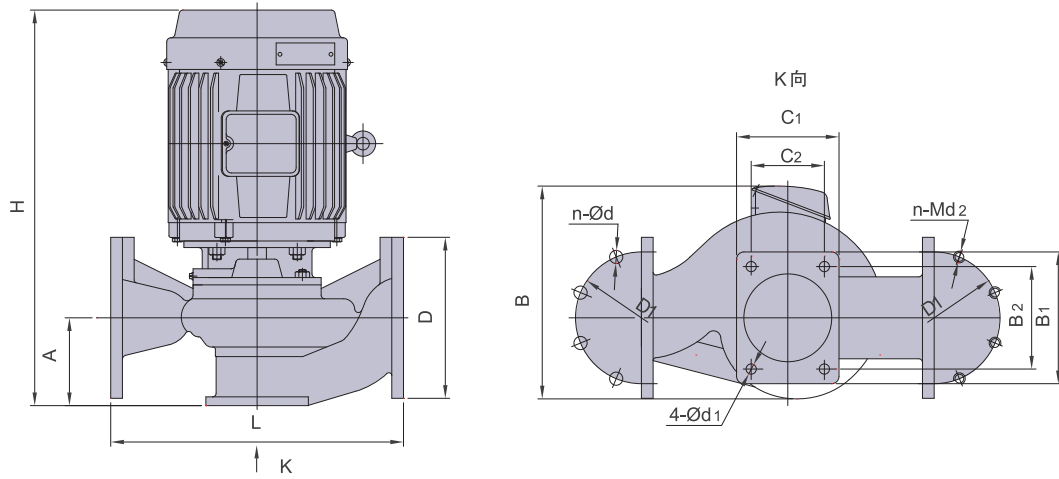

(2P)

型号 Type	外形尺寸 Overall dimension				安装尺寸 Installation dimension				法兰尺寸 Flange size			
	L	B	H	C ₁ ×B ₁	A	C ₂ ×B ₂	Ø d ₁	D	D ₁	n-Ød	n-Md ₂	
L-30-25	250	205	342	80×120	60	50×90	12	115	85	4-Ø14	4-M12	
L-31-40	280	238	381	90×130	70	60×100	14	150	110	4-Ø18	4-M16	
L-32-40	280	251	419	90×130	70	60×100	14	150	110	4-Ø18	4-M16	
L-31-50	280	238	381	90×130	70	60×100	14	150	110	4-Ø18	4-M16	
L-32-50	300	261	447	90×130	90	60×100	14	165	125	4-Ø18	4-M16	
L-33-50	360	280	455	120×170	95	80×130	14	165	125	4-Ø18	4-M16	
L-35-50	360	312	514	120×170	95	80×130	14	165	125	4-Ø18	4-M16	
L-37-50	360	367	551	120×170	95	80×130	14	165	125	4-Ø18	4-M16	
L-32-65	320	271	454	110×160	100	80×130	14	185	145	4-Ø18	4-M16	
L-33-65	320	271	454	110×160	100	80×130	14	185	145	4-Ø18	4-M16	
L-35-65	360	302	516	120×180	105	90×150	14	185	145	4-Ø18	4-M16	
L-37-65	360	355	557	120×180	105	90×150	14	185	145	4-Ø18	4-M16	
L-310-65	360	355	572	120×180	105	90×150	14	185	145	4-Ø18	4-M16	
L-35-80	360	302	522	140×180	110	100×140	14	200	160	8-Ø18	8-M16	
L-37-80	430	354	579	140×200	120	100×160	18	200	160	8-Ø18	8-M16	
L-310-80	430	355	592	140×200	120	100×160	18	200	160	8-Ø18	8-M16	
L-315-80	430	434	714	140×200	120	100×160	18	200	160	8-Ø18	8-M16	
L-320-80	520	434	721	140×200	125	100×160	18	200	160	8-Ø18	8-M16	
L-325-80	520	434	825	140×200	125	100×160	18	200	160	8-Ø18	8-M16	
L-330-80	540	537	847	140×200	130	100×160	18	200	160	8-Ø18	8-M16	
L-340-80	600	535	894	190×280	140	150×240	18	200	160	8-Ø18	8-M16	
L-35-100	400	302	541	150×180	120	120×150	14	220	180	8-Ø18	8-M16	
L-37-100	400	355	582	150×180	120	120×150	14	220	180	8-Ø18	8-M16	
L-310-100	400	355	597	150×180	120	120×150	14	220	180	8-Ø18	8-M16	
L-315-100	450	434	734	160×200	135	120×160	18	220	180	8-Ø18	8-M16	
L-320-100	450	434	734	160×200	135	120×160	18	220	180	8-Ø18	8-M16	
L-325-100	540	434	852	160×220	140	120×180	18	220	180	8-Ø18	8-M16	
L-330-100	540	537	863	160×220	140	120×180	18	220	180	8-Ø18	8-M16	
L-340-100	540	535	888	160×220	140	120×180	18	220	180	8-Ø18	8-M16	
L-350-100	600	560	959	190×280	140	150×240	18	220	180	8-Ø18	8-M16	
L-360-100	640	587	960	160×220	145	120×180	18	220	180	8-Ø18	8-M16	
L-375-100	640	632	968	160×220	145	120×180	18	220	180	8-Ø18	8-M16	
L-3100-100	640	796	1062.5	160×220	145	120×180	18	220	180	8-Ø18	8-M16	
L-360-150	640	564	1001	200×280	190	160×240	18	285	240	8-Ø22	8-M20	
L-375-150	710	640	1038	250×300	205	210×260	22	285	240	8-Ø22	8-M20	
L-3100-150	710	796	1132	250×300	205	210×260	22	285	240	8-Ø22	8-M20	



外形及安装尺寸 Installation dimensions

(4P)

型号 Type	外形尺寸 Overall dimension				安装尺寸 Installation dimension			法兰尺寸 Flange size			
	L	B	H	C ₁ ×B ₁	A	C ₂ ×B ₂	∅d ₁	D	D ₁	n-∅d	n-Md ₂
L-32-65	360	293	456	120×180	105	90×150	14	185	145	4-∅18	4-M16
L-33-65	450	319	508	120×180	105	90×150	14	185	145	4-∅18	4-M16
L-35-65	500	348	525	120×180	110	90×150	18	200	145	4-∅18	4-M16
L-35-65(I)	500	348	525	120×180	110	90×150	18	200	145	4-∅18	4-M16
L-37-65	580	409	610	140×200	130	100×160	18	200	145	4-∅18	4-M16
L-33-80	520	329	528	140×200	125	100×160	18	200	160	8-∅18	8-M16
L-35-80	520	342	538	140×200	125	100×160	18	200	160	8-∅18	8-M16
L-37-80	540	389	610	140×200	130	100×160	18	200	160	8-∅18	8-M16
L-310-80	580	409	648	140×200	130	100×160	18	200	160	8-∅18	8-M16
L-315-80	580	466	732	140×200	130	100×160	18	200	160	8-∅18	8-M16
L-35-100(I)	540	350	565	160×220	140	120×180	18	220	180	8-∅18	8-M16
L-37-100	540	377	626	160×220	140	120×180	18	220	180	8-∅18	8-M16
L-310-100	540	377	664	160×220	140	120×180	18	220	180	8-∅18	8-M16
L-315-100	640	474	755	160×220	145	120×180	18	220	180	8-∅18	8-M16
L-320-100	640	474	799	160×220	145	120×180	18	220	180	8-∅18	8-M16
L-325-100	720	534.6	870	160×220	150	120×180	18	220	180	8-∅18	8-M16
L-330-100	720	534.6	870	160×220	150	120×180	18	220	180	8-∅18	8-M16
L-37-150	640	398	674	200×280	190	160×240	18	285	240	8-∅22	8-M20
L-310-150	640	398	712	200×280	190	160×240	18	285	240	8-∅22	8-M20
L-315-150	640	450	796	200×280	190	160×240	18	285	240	8-∅22	8-M20
L-320-150	710	460	868	250×300	205	210×260	22	285	240	8-∅22	8-M20
L-320-150(I)	710	460	868	250×300	205	210×260	22	285	240	8-∅22	8-M20
L-325-150	770	548	938	250×300	205	210×260	22	285	240	8-∅22	8-M20
L-330-150	770	548	938	250×300	205	210×260	22	285	240	8-∅22	8-M20
L-315-200	720	466	829	270×320	210	230×280	22	340	295	8-∅22	8-M20
L-320-200	720	466	873	270×320	210	230×280	22	340	295	8-∅22	8-M20
L-325-200	720	537	944	280×340	210	230×280	22	340	295	8-∅22	8-M20
L-325-200(I)	760	517	968	280×360	230	230×320	22	340	295	8-∅22	8-M20
L-330-200	760	517	968	280×360	230	230×320	22	340	295	8-∅22	8-M20
L-340-200	760	517	994	280×360	230	230×320	22	340	295	8-∅22	8-M20
L-350-200	800	560	1069	280×340	250	230×290	22	340	295	8-∅22	8-M20
L-360-200	940	599	1080	280×400	231	230×360	22	340	295	8-∅22	8-M20
L-375-200	940	644	1089	280×400	231	230×360	22	340	295	8-∅22	8-M20
L-3100-200	960	807	1188	270×400	235	230×360	22	340	295	8-∅22	8-M20
L-3125-200	960	807	1188	270×400	235	230×360	22	340	295	8-∅22	8-M20
L-325-250	840	567	1023	280×360	275	240×320	18	395	350	12-∅22	12-M20
L-330-250	840	567	1023	280×360	275	240×320	18	395	350	12-∅22	12-M20
L-340-250	890	572	1066	320×380	282	260×320	22	395	350	12-∅22	12-M20
L-350-250	890	597	1131	320×380	282	260×320	22	395	350	12-∅22	12-M20
L-360-300	1200	658	1229	450×500	360	400×450	23	445	400	12-∅22	12-M20
L-375-300	1200	672	1238	450×500	360	400×450	23	445	400	12-∅22	12-M20
L-3100-300	1200	807	1332	450×500	360	400×450	23	445	400	12-∅22	12-M20
L-3125-300	1200	807	1389	450×500	360	400×450	23	445	400	12-∅22	12-M20



如蒙洽询请指示下列各项:

For further details, please fulfill the chart below.

客户
Customer _____

承办人员
Undertaker _____

工程名称
Name of project _____

工程地点
Address of project _____

电话
Telephone _____

传真
Fax _____

订购机型
Type _____

订购数量
Quantity _____

性能参数 Performance parameters	介质名称 Medium name		* 介质温度(°C) Medium temperature		
	* 流量(m ³ /h) Capacity		* 扬程(m) Head		
	* 进口压力(MPa) Inlet pressure				
	轴封型式 Seal form	<input type="checkbox"/> 机械密封 (标准配置) Mechanical seal(standard) <input type="checkbox"/> 其他 _____ Other			
	主要部件材质 Major parts' material	泵体 Pump body	<input type="checkbox"/> HT200 标准配置 Standard	<input type="checkbox"/> 其他 Other	
		叶轮 Impeller	<input type="checkbox"/> HT200 标准配置 Standard	<input type="checkbox"/> 其他 Other	
		轴 Shaft	<input type="checkbox"/> 2Cr13 标准配置 Standard	<input type="checkbox"/> 其他 Other	
	泵安装型式 Installation type	<input type="checkbox"/> 从传动端看泵方向为顺时针方向旋转(标准配置) Clockwise rotation looking from motor to pump body(standard). <input type="checkbox"/> 从传动端看泵方向为逆时针方向旋转 Anti-clock wise rotation looking from motor to pump body.			
	电源 Power	电压(V) Voltage		频率(Hz) Frequency	
	电机 Moter	型号 Type		功率(kW) Power	
防护等级 IP code			绝缘要求 Class of insulation		
其他要求 Other requirement					
备注 Notes	1. 出厂标准配置不含地脚螺栓和吐出锥管。 The foundation bolt and discharge cone are not in the ex-factory standard layout. 2. 以上资料请尽可能填写完整, 以便于选择最佳机型, 项目前加注“*”者, 请务必填写。 Please fill in the parameter lists as complete as possible. The item with “*” must be filled.				



欢迎索取以下产品型录



泵系列

潜水泵系列 | 陆上泵系列 | 特种泵系列



搅拌推流系列

搅拌机系列 | 推流器系列



供氧曝气系列

曝气机系列 | 曝气盘系列 | 曝气管系列



风机系列

磁悬浮鼓风机 | 空气悬浮鼓风机 | 三叶罗茨鼓风机系列



污泥处理设备

带式脱水机 | 厢式压滤机 | 叠螺式脱水机 | 污泥干化设备 | 浅层高效气浮设备



智能化系列

EP6 物联监控管理系统 | 空气质量管理系统 | RS-485 传感器



反应器及套装设备

芬顿反应系统 | MBR膜生物反应器 | 预制泵站 | 一体化污水处理设备



耗材药剂及相关设备

生物绳 | PAC 聚合氯化铝 | PAM 聚丙烯酰胺 | 泡药设备



水处理系统专业合作伙伴

免费咨询电话

400-657-9066

本型录内容如有变更，恕不另行通知。
We reserve the right to change content without notice.

川源(中国)机械有限公司版权所有 all rights reserved. CY-15

