



川源(中国)机械有限公司
GSD (China) Co., Ltd.



CVD/CHD

干井式不堵塞泵

CVD/CHD dry pit non-clog pump

CVD/CHD 干井式不堵塞泵

CVD/CHD dry pit non-clog pump



用途

- 污水处理厂污泥及污物抽送。
- 生活废水及工厂污水抽送。

Application

- Wastewater treatment plant sewage and sludge pumping equipment.
- Municipal and industrial wastewater pumping equipment.

型号说明 Type description

CVD-5 15-150

出口口径	Outlet Diameter(mm)
配套功率	Rated power(kW)
频率: 50Hz	Frequency 5: 50 Hz
CVD: 立式竖轴	CVD: Vertical type
CHD: 卧式横轴	CHD: Horizontal type

特点

- 干井式结构易于安装维护保养，依安装现场空间大小及配管之不同，有立式竖轴及卧式横轴两种型式可供选择。
- 叶轮为不堵塞型结构，可使污物轻易通过，使流道不致堵塞，组装前均经过动平衡校正。
- 泵体及竖轴式之吸入弯管均设有清除异物之除污盖，毋须拆卸泵浦即可轻易清除异物及污泥，便于定时保养，减少故障的机率。
- 使用全封闭滚珠轴承，可承受泵浦工作时所产生之轴向推力。
- 采用机械密封，机械密封材质为SiC-SiC。

Features

- Dry pit construction is easily installed and maintained. there are vertical type and horizontal type to choose depending on installation space and piping layout.
- Impeller is non-clog type, it makes sludge and sewage free to pass the flow passages. The impeller is dynamically balanced before assembly the pump.
- Pump casing and suction elbow pipe both have handhole cover to clear the foreign objects. We can easily clear Foreign body and sludge without disassemble the other components, It is convient to be cared and maintained, and can prevent pump from being out of order.
- Full closed ball bearings are added protection for high loads.
- Shaft seal is mechanical seal. The material of mechanical seal is SiC.



结构简图 Construction

CHD

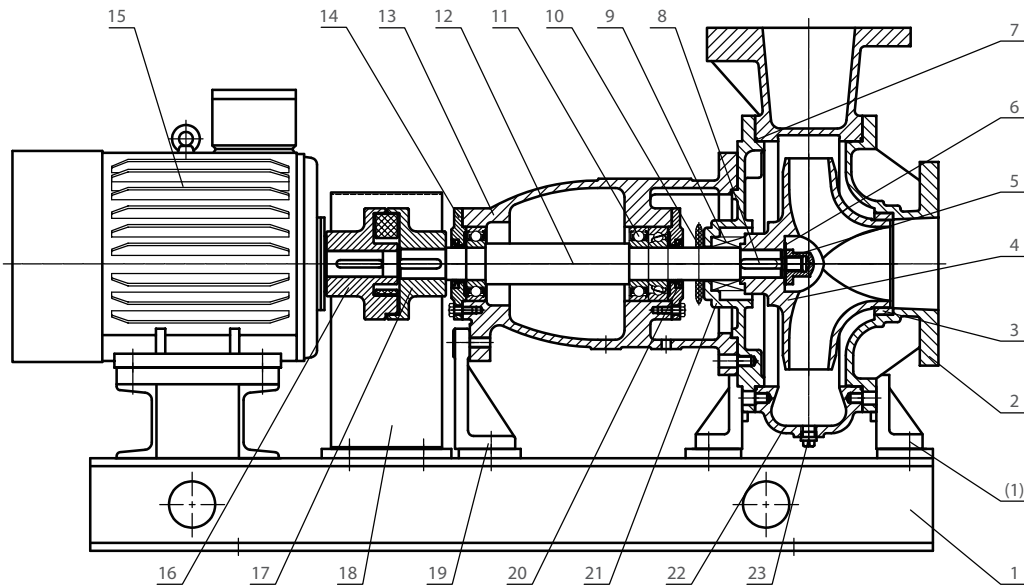

CVD

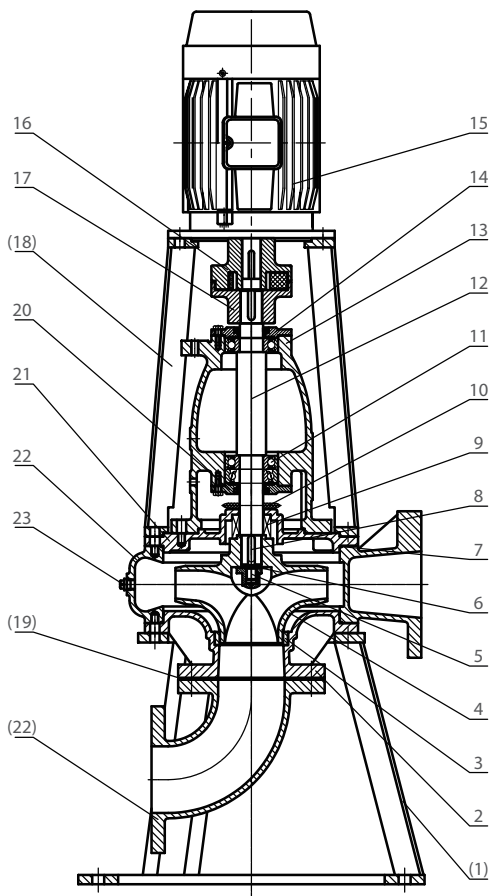

NO.	名称	Name	材质	
			GB	JIS
1	机座	Base	Q235A	SS400
(1)	泵体支架	Pump stand	Q235A	SS400
2	前盖	Front cover	HT200	FC200
3	密封环	Seal ring	ZCuSn10Pb5	LBC2
4	叶轮	Impeller	HT200	FC200
5	叶轮螺母	Impeller nut	06Cr19Ni10	SUS304
6	止动垫圈	Lock wash	06Cr17Ni12Mo2	SUS316
7	O型圈	O-ring	NBR	NBR
8	键	Key	30Cr13	SUS420J ₂
9	机械密封	Mechanical seal	SiC-SiC	SiC-SiC
10	挡水圈	Water baf-fing ring	NBR	NBR
11	轴承	Bearing	-	-
12	主轴	Shaft	30Cr13	SUS420J ₂
13	轴承体	Bearing body	HT200	FC200
14	轴承盖	Bearing cover	HT200	FC200
15	电机	Motor	-	-
16	电机联轴器	Coupling	HT200	FC200
17	泵联轴器	Pump coupling	HT200	FC200
18	联轴器罩	Coupling cover	Q235A	SS400
(18)	电机支架	Motor stand	Q235A	SS400
19	轴承体支架	Bearing stand	HT200	FC200
(19)	法兰垫片	Flange gasket	NBR	NBR
20	VD密封圈	VD Seal ring	Viton	Viton
21	后盖	Back cover	HT200	FC200
22	泵体	Pump body	HT200	FC200
(22)	弯管	Bent pipe	HT200	FC200
23	丝堵	Plug	06Cr19Ni10	SUS304



型谱图 Performance chart

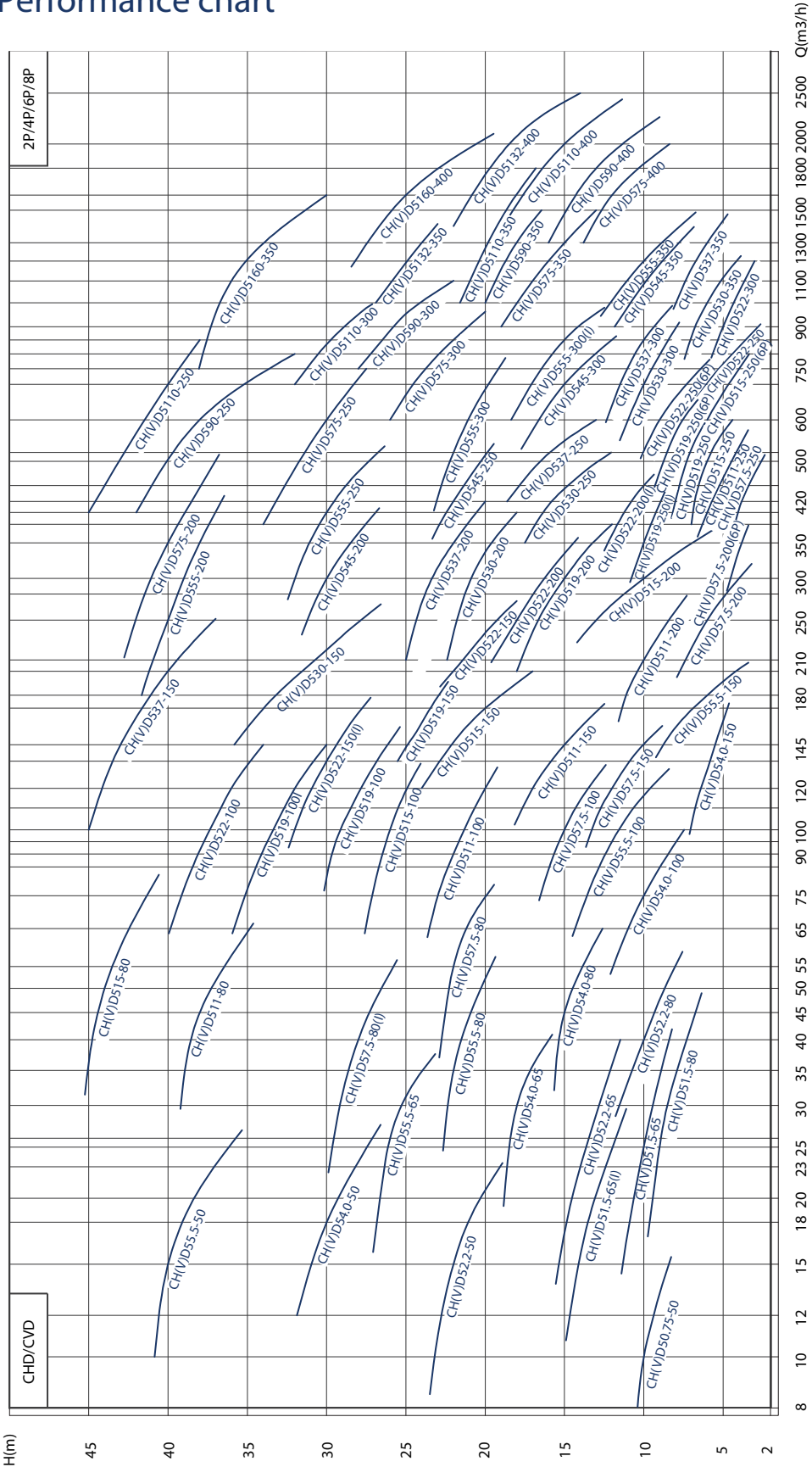

性能参数 Performance parameters

(2P/4P/6P/8P)

泵型号 Pump model	转速 Speed (r/min)	流量 Capacity (m ³ /h)	扬程 Head (m)	效率 Eff. (%)	电机功率 Motor power (kW)	口径 Dia. (mm)	重量 Weight (kg)
CVD50.75-50 CHD50.75-50	1450	10	10	50	0.75	50	102 89
CVD51.5-65 CHD51.5-65	1450	25	10	60	1.5	65	155 106
CVD51.5-65(I) CHD51.5-65(I)	1450	18	13.5	60	1.5	65	155 115
CVD52.2-50 CHD52.2-50	2900	15	22	52	2.2	50	95 90
CVD52.2-65 CHD52.2-65	1450	23	14	60	2.2	65	124 116
CVD54.0-50 CHD54.0-50	2900	18	30	50	4	50	120 125
CVD54.0-65 CHD54.0-65	1450	30	18	55	4	65	170 156
CVD55.5-50 CHD55.5-50	2900	15	40	43	5.5	50	130 125
CVD55.5-65 CHD55.5-65	1450	26	26	50	5.5	65	256 211
CVD51.5-80 CHD51.5-80	1450	30	8.5	60	1.5	80	131 108
CVD52.2-80 CHD52.2-80	1450	40	10	60	2.2	80	175 116
CVD54.0-80 CHD54.0-80	1450	45	15	62	4	80	190 171
CVD55.5-80 CHD55.5-80	1450	35	22	55	5.5	80	220 190
CVD57.5-80 CHD57.5-80	1450	55	22	62	7.5	80	218 213
CVD57.5-80(I) CHD57.5-80(I)	1450	36	28.5	50	7.5	80	230 210
CVD511-80 CHD511-80	1450	45	38	60	11	80	350 338
CVD515-80 CHD515-80	1450	50	44	51	15	80	367 355
CVD54.0-100 CHD54.0-100	1450	75	10	70	4	100	190 171
CVD55.5-100 CHD55.5-100	1450	95	12	68	5.5	100	220 191
CVD57.5-100 CHD57.5-100	1450	100	15	70	7.5	100	245 211



性能参数 Performance parameters

(2P/4P/6P/8P)

泵型号 Pump model	转速 Speed (r/min)	流量 Capacity (m ³ /h)	扬程 Head (m)	效率 Eff. (%)	电机功率 Motor power (kW)	口径 Dia. (mm)	重量 Weight (kg)
CVD511-100 CHD511-100	1450	90	22	68	11	100	332 335
CVD515-100 CHD515-100	1450	100	26	65	15	100	370 319
CVD519-100 CHD519-100	1450	110	28.5	66	18.5	100	430 348
CVD519-100I CHD519-100I	1450	120	32	64	18.5	100	450 365
CVD522-100 CHD522-100	1450	120	36	65	22	100	460 380
CVD54.0-150 CHD54.0-150	1450	130	6	72	4	150	230 167
CVD55.5-150 CHD55.5-150	1450	180	6	73	5.5	150	260 213
CVD57.5-150 CHD57.5-150	1450	120	12	70	7.5	150	275 221
CVD511-150 CHD511-150	1450	145	15	72	11	150	334 308
CVD515-150 CHD515-150	1450	160	21	72	15	150	385 335
CVD519-150 CHD519-150	1450	170	23.5	73	18.5	150	435 396
CVD522-150 CHD522-150	1450	200	22	73	22	150	465 420
CVD522-150(I) CHD522-150(I)	1450	135	30	69	22	150	465 420
CVD530-150 CHD530-150	1450	220	30	75	30	150	500 480
CVD537-150 CHD537-150	1450	200	40	75	37	150	720 680
CVD57.5-200 CHD57.5-200	1450	250	6	72	7.5	200	262 291
CVD57.5-200 CHD57.5-200	980	300	4.5	60	7.5	200	370 340
CVD511-200 CHD511-200	1450	210	10	70	11	200	395 303
CVD515-200 CHD515-200	1450	300	10	72	15	200	380 344
CVD519-200 CHD519-200	1450	300	15	75	18.5	200	410 384



性能参数 Performance parameters

(2P/4P/6P/8P)

泵型号 Pump model	转速 Speed (r/min)	流量 Capacity (m ³ /h)	扬程 Head (m)	效率 Eff. (%)	电机功率 Motor power (kW)	口径 Dia. (mm)	重量 Weight (kg)
CVD522-200 CHD522-200	1450	250	18	72	22	200	525 483
CVD522-200(I) CHD522-200(I)	1450	450	10	72	22	200	495 450
CVD530-200 CHD530-200	980	330	20	76	30	200	1050 1080
CVD537-200 CHD537-200	980	350	22	75	37	200	1030 960
CVD545-200 CHD545-200	980	300	30	72	45	200	1135 1085
CVD555-200 CHD555-200	980	250	40	65	55	200	1380 1300
CVD575-200 CHD575-200	980	350	40	70	75	200	1800 1980
CVD57.5-250 CHD57.5-250	980	400	4	65	7.5	250	430 400
CVD511-250 CHD511-250	980	400	6	66	11	250	530 550
CVD515-250 CHD515-250	1450	500	6	71	15	250	471 490
CVD515-250 CHD515-250	980	600	6	72	15	250	550 580
CVD519-250 CHD519-250	1450	600	6	71	18.5	250	510 515
CVD519-250(I) CHD519-250(I)	1450	350	10	71	18.5	250	640 520
CVD519-250 CHD519-250	980	600	7.5	75	18.5	250	650 620
CVD522-250 CHD522-250	1450	700	6	73	22	250	515 520
CVD522-250 CHD522-250	980	600	9	75	22	250	680 650
CVD530-250 CHD530-250	980	460	14.5	75	30	250	1080 938
CVD537-250 CHD537-250	980	500	16.5	77	37	250	1600 1070
CVD545-250 CHD545-250	980	420	22	76	45	250	1650 1173
CVD555-250 CHD555-250	980	400	30	76	55	250	1760 1920



性能参数 Performance parameters

(2P/4P/6P/8P)

泵型号 Pump model	转速 Speed (r/min)	流量 Capacity (m ³ /h)	扬程 Head (m)	效率 Eff. (%)	电机功率 Motor power (kW)	口径 Dia. (mm)	重量 Weight (kg)
CVD575-250 CHD575-250	980	600	30	76	75	250	1815 1980
CVD590-250 CHD590-250	980	600	38	76	90	250	1890 2100
CVD5110-250 CHD5110-250	980	700	40	78	110	250	2100 2300
CVD522-300 CHD522-300	980	900	5	60	22	300	890 850
CVD530-300 CHD530-300	980	700	10	75	30	300	1650 1110
CVD537-300 CHD537-300	980	850	10	77	37	300	1700 1200
CVD545-300 CHD545-300	980	700	15	78	45	300	1760 1310
CVD555-300 CHD555-300	980	520	22	78	55	300	1800 1300
CVD555-300(I) CHD555-300(I)	980	850	15	78	55	300	1815 1280
CVD575-300 CHD575-300	980	850	22	78	75	300	1870 2040
CVD590-300 CHD590-300	980	950	25	79	90	300	1980 2160
CVD5110-300 CHD5110-300	980	950	28	80	110	300	2200 2400
CVD530-350 CHD530-350	980	1000	6	75	30	350	1300 1100
CVD537-350 CHD537-350	980	1300	6	77	37	350	1400 1150
CVD545-350 CHD545-350	980	1100	10	75	45	350	1600 1200
CVD555-350 CHD555-350	980	1200	10	75	55	350	1670 1270
CVD575-350 CHD575-350	980	1300	15	78	75	350	1980 2160
CVD590-350 CHD590-350	980	1300	18	78	90	350	2050 2230
CVD5110-350 CHD5110-350	980	1600	18	79	110	350	2250 2450
CVD5132-350 CHD5132-350	740	1300	24	75	132	350	2450 2650



性能参数 Performance parameters

(2P/4P/6P/8P)

泵型号 Pump model	转速 Speed (r/min)	流量 Capacity (m ³ /h)	扬程 Head (m)	效率 Eff. (%)	电机功率 Motor power (kW)	口径 Dia. (mm)	重量 Weight (kg)
CVD5160-350 CHD5160-350	740	1100	36	75	160	350	2950 3150
CVD575-400 CHD575-400	980	1600	12	80	75	400	2200 2400
CVD590-400 CHD590-400	980	1800	13	80	90	400	2220 2450
CVD5110-400 CHD5110-400	980	2000	15	79	110	400	2640 2880
CVD5132-400 CHD5132-400	740	2200	17	81	132	400	2850 3100
CVD5160-400 CHD5160-400	740	1600	25	76	160	400	3200 3600



欢迎索取以下产品型录



泵系列

潜水泵系列 | 陆上泵系列 | 特种泵系列



搅拌推流系列

搅拌机系列 | 推流器系列



供氧曝气系列

曝气机系列 | 曝气盘系列 | 曝气管系列



风机系列

磁悬浮鼓风机 | 空气悬浮鼓风机 | 三叶罗茨鼓风机系列



污泥处理设备

带式脱水机 | 厢式压滤机 | 叠螺式脱水机 | 污泥干化设备 | 浅层高效气浮设备



智能化系列

智能设备 | 水务设备健康管理 | 水务系统工艺优化智联管理



反应器及套装设备

芬顿反应系统 | MBR膜生物反应器 | 预制泵站 | 一体化污水处理设备



耗材药剂及相关设备

生物绳 | PAC 聚合氯化铝 | PAM 聚丙烯酰胺 | 泡药设备



水处理系统专业合作伙伴

免费咨询电话

400-657-9066

本型录内容如有变更，恕不另行通知。
We reserve the right to change content without notice.

川源(中国)机械有限公司版权所有 all rights reserved. CY-12

